

Notes: Functions only available on certain products
 L U E C I S SD Q W B 6 - Only available on PYBD-SF6

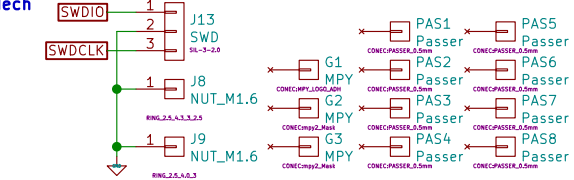

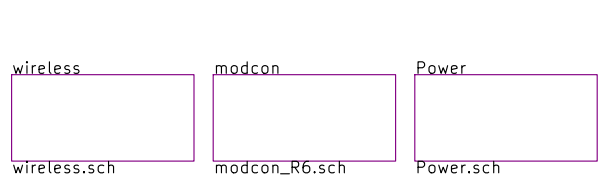
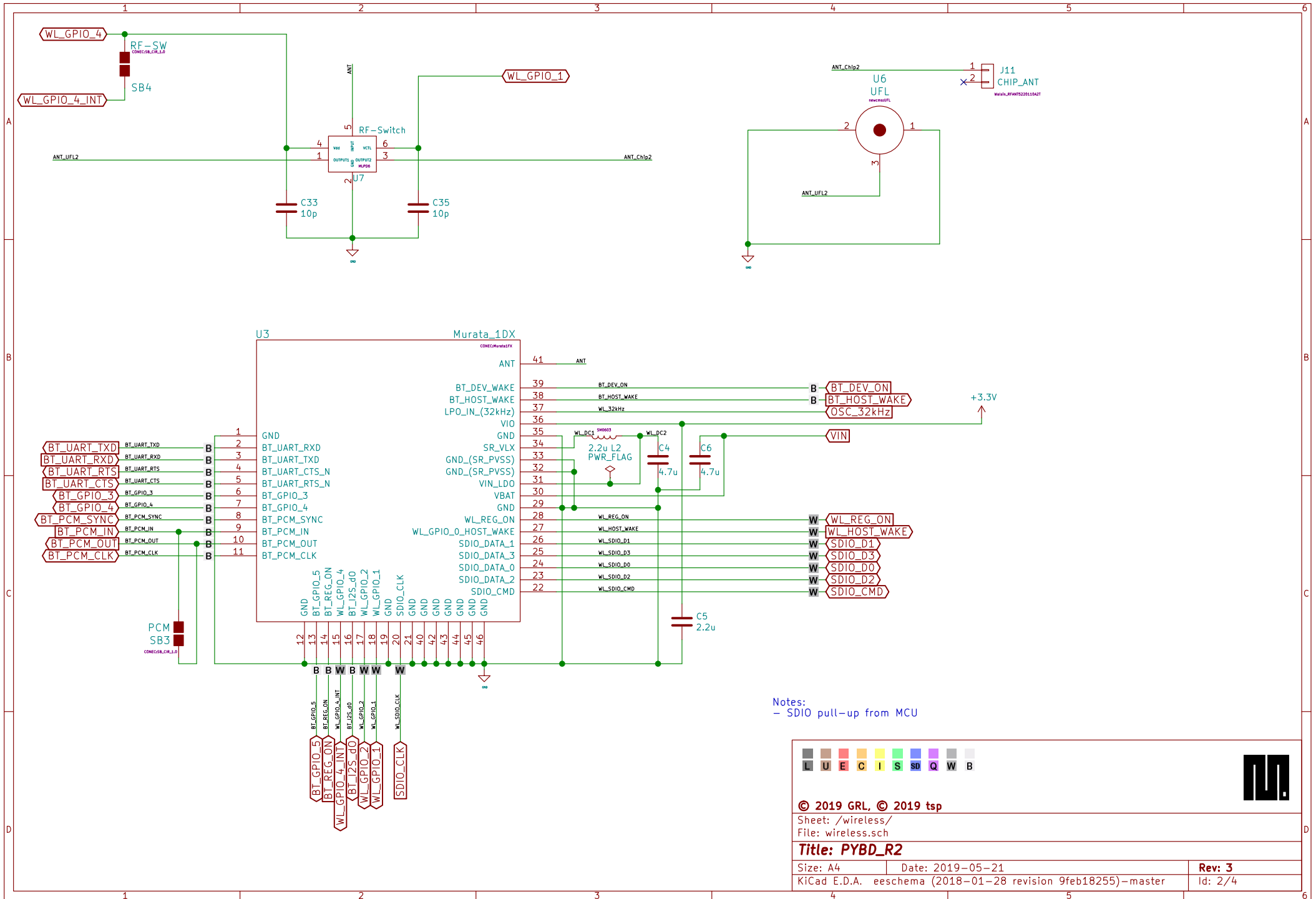

Notes:
 - SDIO pull-up from MCU

© 2019 GRL, © 2019 tsp										
Sheet: /wireless/ File: wireless.sch										
Title: PYBD_R2										
Size: A4					Date: 2019-05-21					Rev: 3
KiCad E.D.A. eeschema (2018-01-28 revision 9feb18255)-master										Id: 2/4

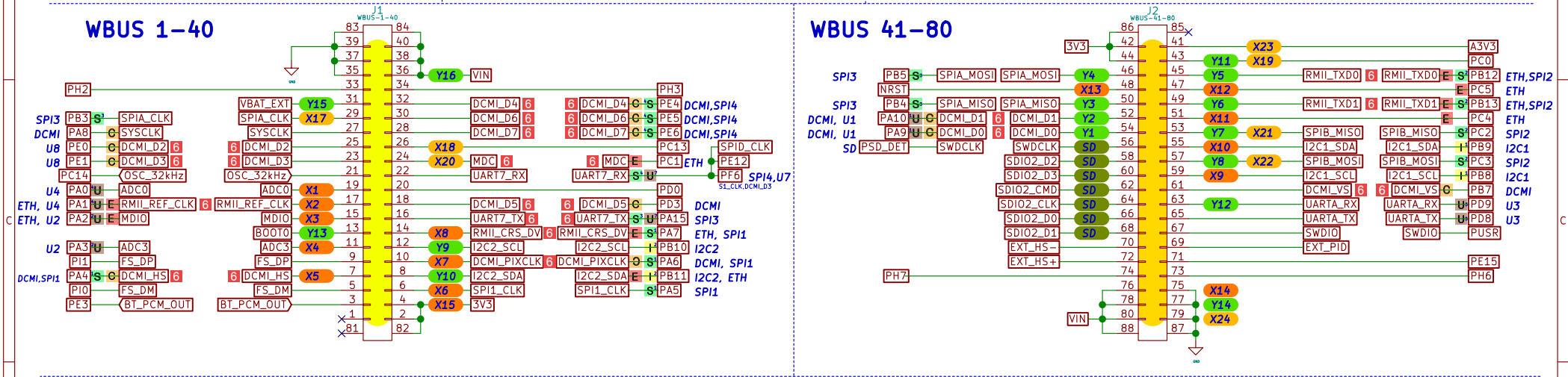
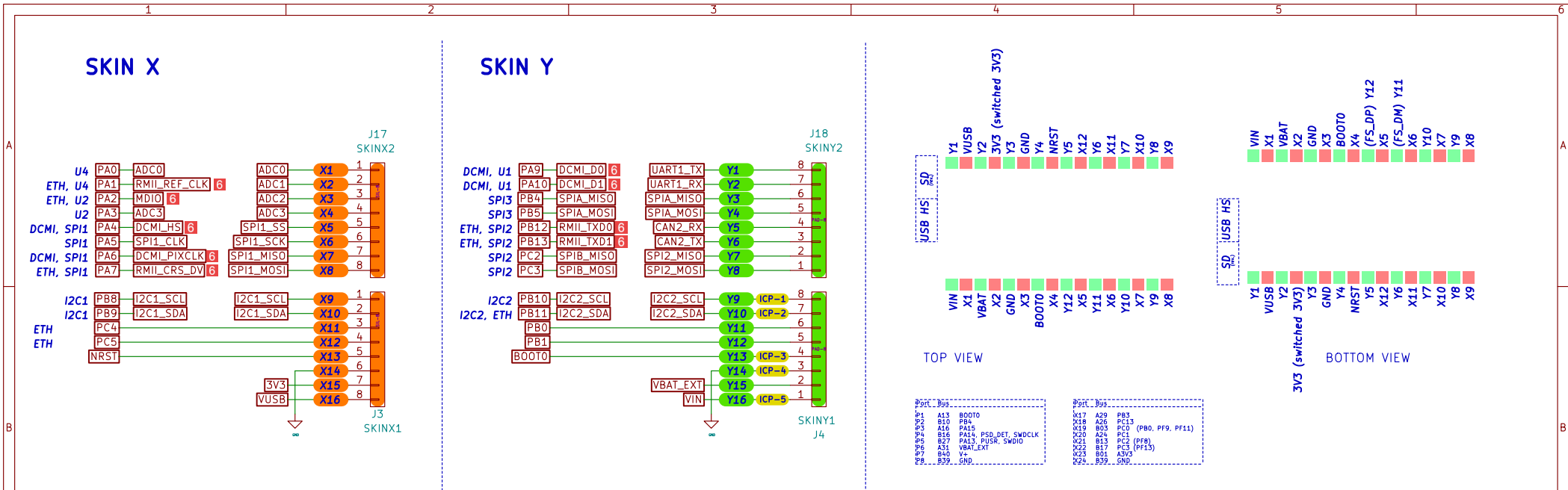

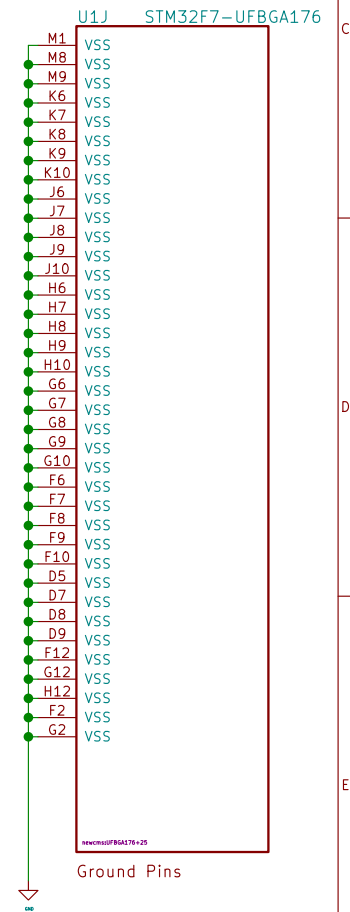
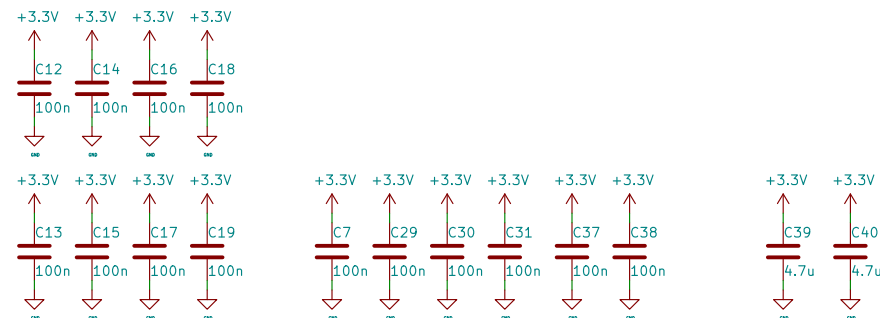
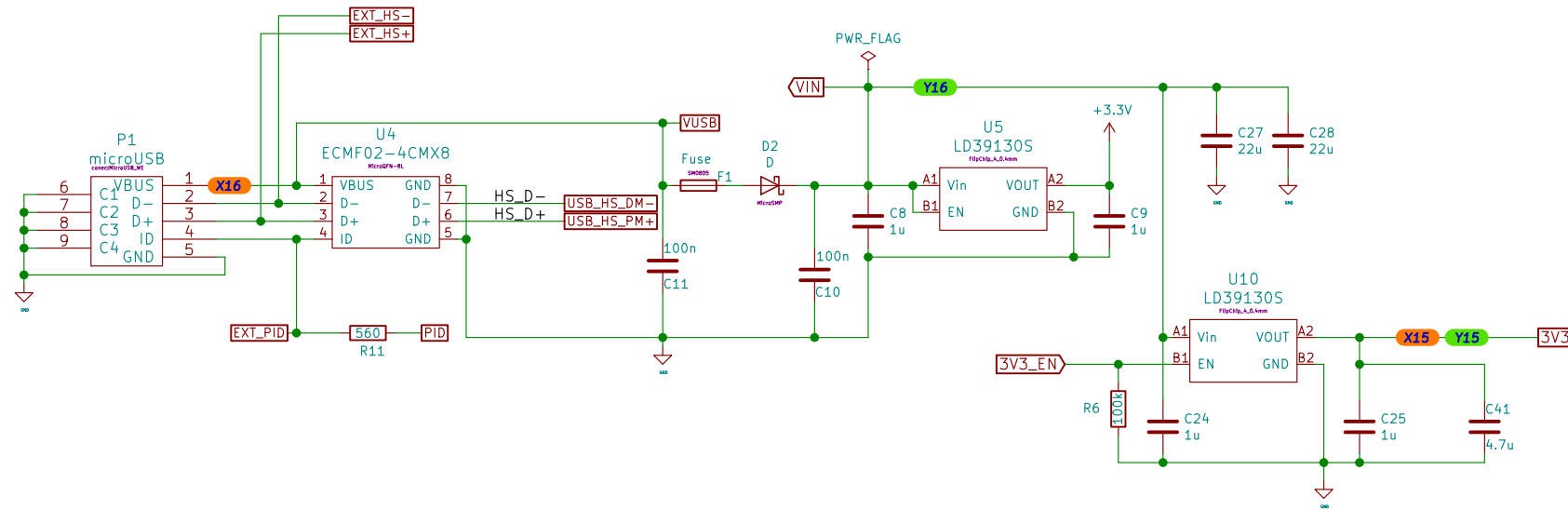
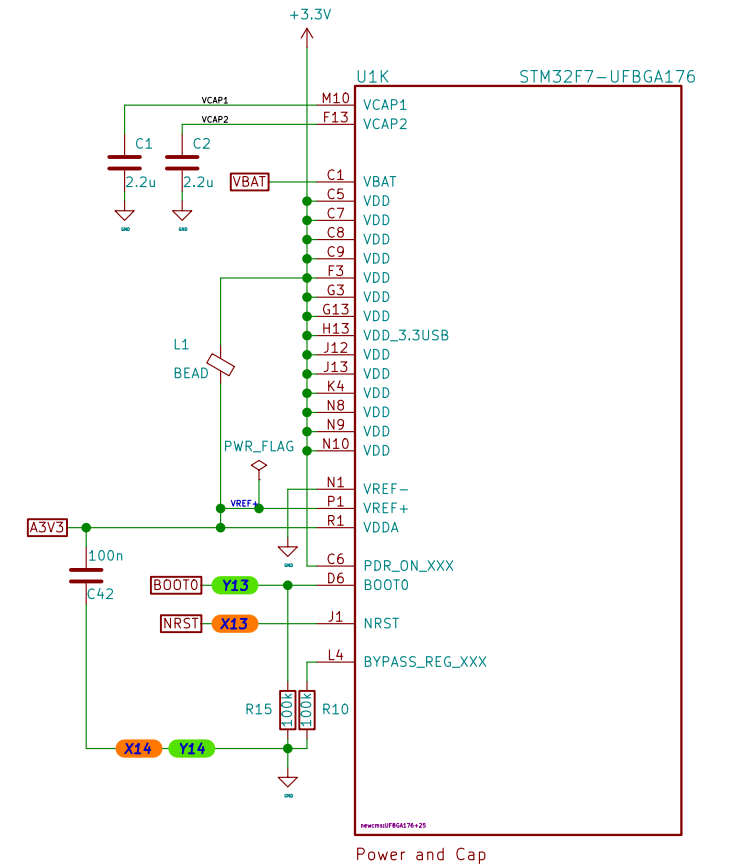
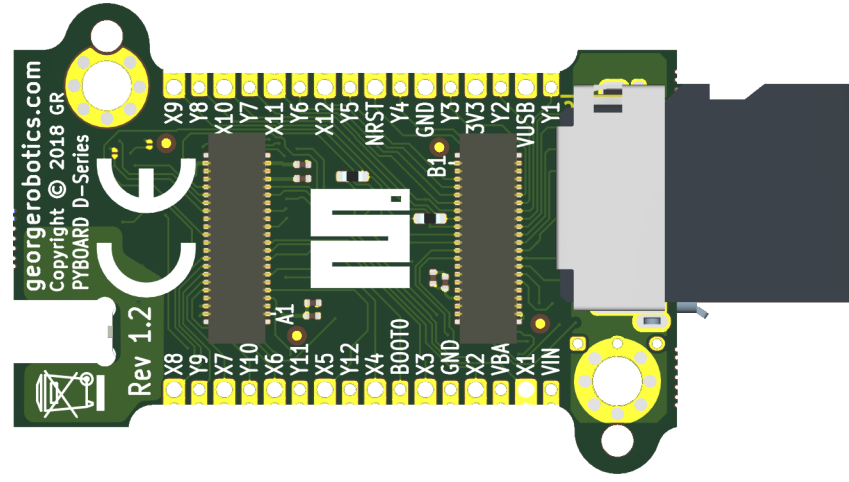
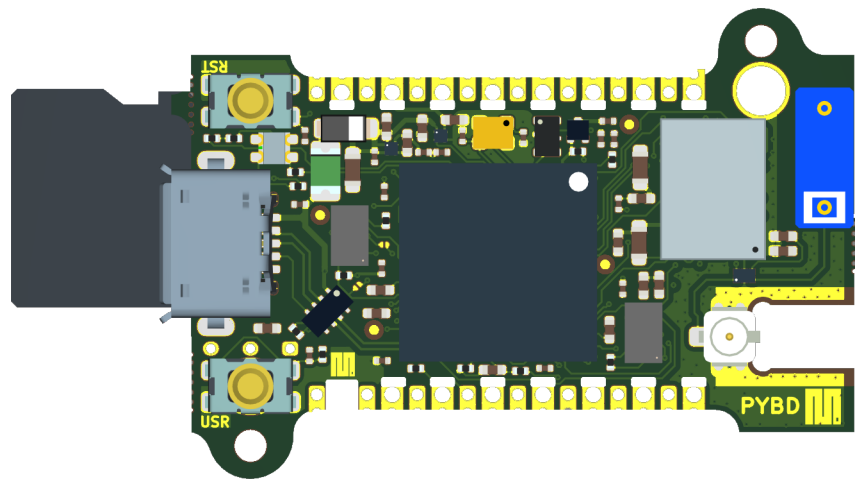

L
 U
 E
 C
 I
 S
 S
 Q
 W
 B

© 2019 GRL, © 2019 tsp
 Sheet: /Power/
 File: Power.sch
Title: PYBD_R2
 Size: A3 Date: 2019-05-21 Rev: 3
 KiCad E.D.A. eeschema (2018-01-28 revision 9feb18255)-master Id: 4/4